

MULTI-PURPOSE SERIES

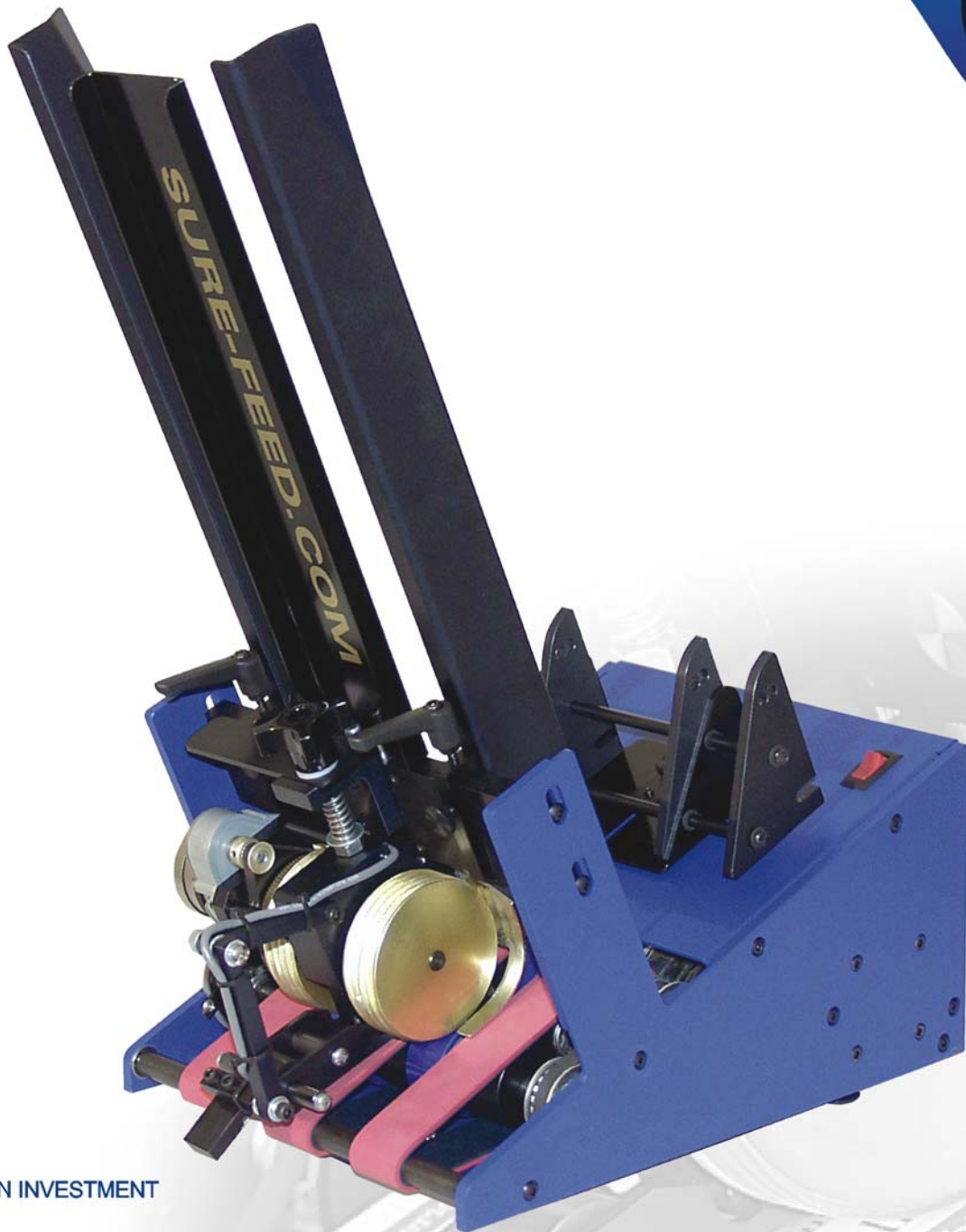

- ▶▶ RETURN ON INVESTMENT
- ▶▶ REDUCE SETUP TIME
- ▶▶ ONE FEEDER FOR TWO DIFFERENT APPLICATIONS
- ▶▶ CONSISTENT FEEDING
- ▶▶ EASILY INTEGRATES INTO THE WORK CELL

TYPE OF UNIT: INK JET / TABBER FEEDER

Ink-Jet Applications: Designed to interface with all makes and models of ink jet bases and tabbers. Great for all continuous feed applications. Also for in-line conveyor applications.

▶▶ For more information contact your authorized dealer at: 1-800-INSERTER(467-3783)

KEY FEATURES

PRODUCT GUIDE

Keeps product uniform.

HEAVY-DUTY FEEDER BODY CONSTRUCTION

1/4" thick powder coated feeder body construction ensures strength and durability.

DYNAMIC ROTATION TECHNOLOGY

This feature comes standard in our top of the line feeders & inserters. The Gold Separator Wheel counter rotates against the flow of material which gives the separator o-rings even wear and no "flat spots". The large diameter makes for a perfect pre-shingle prior to the nip point.

NON-GLAZING FORMULA BELTS

This eliminates the slip feeding issues created by large product, over weight feed stacks, slick or coated stock.

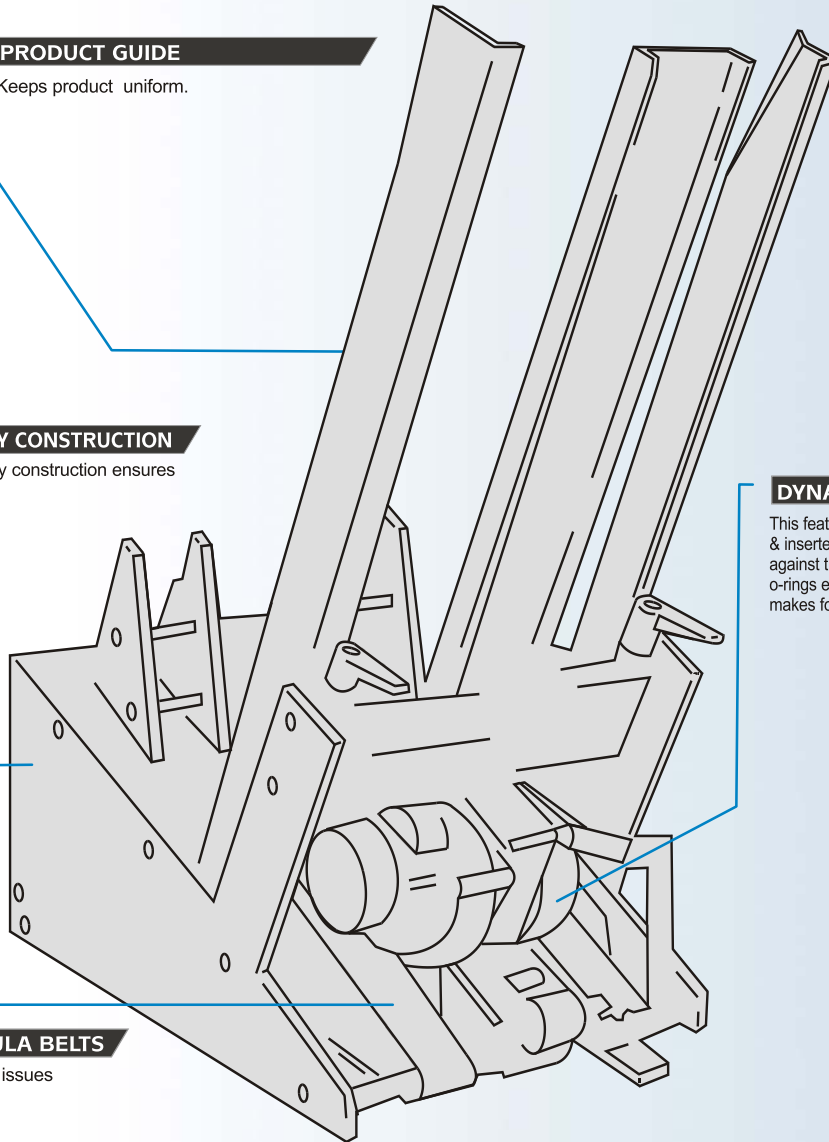

SPECIFICATIONS & APPLICATIONS



- ▶ The Multi-Purpose Feeder can be added as a Replace-A-Station to your Gripper Arm Inserter just like our EI Model, then with a flip of a switch you can use it on an Ink Jet.
- ▶ The Se Models come standard with our Patented Dynamic Rotation Technology, the ECO Models feature our Patented "Football" Separator. MP feeders come standard with heavy duty 1/4" thick powder coated side frames, small product guides and variable speed control.
- ▶ The MP feeder can be used for Ink Jetting, tabbing, inserting, coding, scanning and many more.

TECHNICAL SPECIFICATIONS

	SE 900 MP / ECO 900 MP	SE 1200 MP / ECO 1200 MP
Product Size Maximum	9.125" -W x 14"-L	11.5" W x 14" -L
Product Size Minimum	3" -W x 2" - L	3" -W x 2" - L
Product Thickness Max.	.75"	.75"
Product Thickness Min.	.002"	.002"
Hopper Capacity	20" Vertical	20" Vertical
Electrical	120/240 VAC	120/240 VAC
Speed	Variable 20 -320 ft/min.	Variable 20 -500 ft/min.
Drive Motor	Variable DC	Variable DC
Warranty	2 Year Limited	2 Year Limited

All Specifications are subject to change.



Two feeders with a flip of a switch

simply innovative

SURE-FEED ENGINEERING

12050 49th STREET NORTH, CLEARWATER FL. 33762-4301
 PHONE: 727.571.3330 FAX: 727.571.3443 TOLL FREE: 1.800.INSERTER

visit us on the worldwide web at : www.sure-feed.com
 e-mail: sales@sure-feed.com

